



**Mitsui Chemicals**

## **International chemical company uses High Availability Cluster with Open-E JovianDSS**



Mitsui Chemicals Europe GmbH is a chemical subsidiary of Mitsui Chemicals Inc, Tokyo who was seeking a High Availability iSCSI storage system with at least 50TB of usable storage capacity for its existing VMware farm.

The storage system was supposed to be based on Dell hardware. Furthermore, the new SAN system should be operated as an Active-Active cluster. In fact, the old Dell EqualLogic SAN systems, which reached the performance limit, were the decisive reason behind a new solution.

All in all, their most important requirement was the High Availability in day-to-day business, plus all business processes could not be compromised in any way.



# Solution

The customer was offered various performance and capacity oriented disk configurations to choose from.

Soon they were offered the Open-E JovianDSS Active-Active Cluster with two rack servers as storage nodes and two JBOD chassis for the operation of two independent storage pools. During normal operation, each storage node provides one storage pool.

ITgration coordinated the whole design process with the customer and delivered the Open-E JovianDSS Cluster as a turnkey solution. This includes the installation and configuration of Dell hardware, Open-E JovianDSS software, integration into the VMware farm and the customer's Check\_MK monitoring system.

## Configuration

<b>Server</b>	2x DELL PowerEdge R640, 1U
<b>JBOD</b>	2x DELL Storage MD1400, 2U - 12x 3.5" Bay
<b>Processor</b>	2x Intel Xeon Gold 5118 @ 12x 2,3 GHz
<b>RAM</b>	2x 256 GB RAM - expandable
<b>RAID</b>	PERC H840 HBA for JBOD connections
<b>HDD/SSD</b>	Read Cache: 1x 1.6 TB SAS SSD Write Log: 2x 400 GB SAS SSD Hard drive: 9x 8TB 7.2k Near-line SAS HDD Hotspare: 1x Spare Disk Boot: 2x 300 GB SAS Boot-Disk
<b>Ethernet</b>	2x 10 Gbit/s NIC + 2x 1 Gbit/s NIC
<b>Software</b>	Open-E JovianDSS 64TB + 5 Years Premium Support

# Hardware configuration

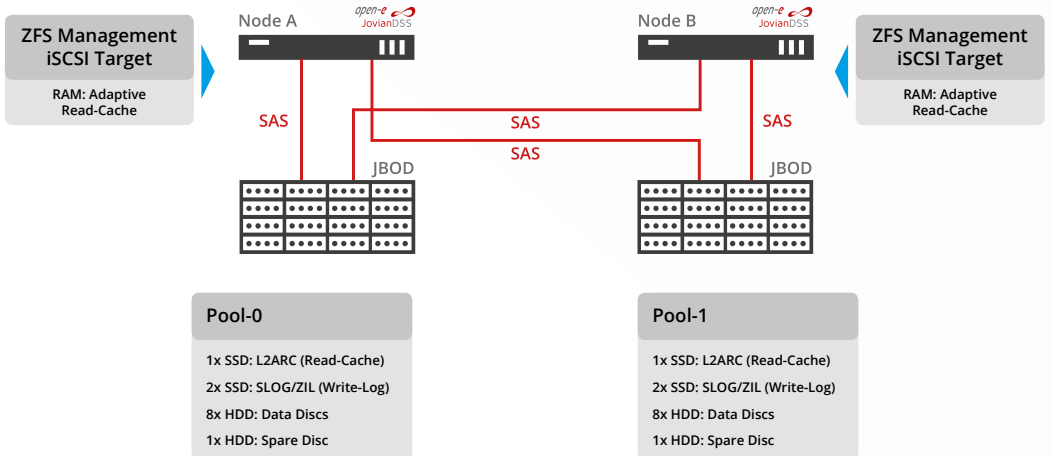

## Customer feedback

Christoph Duis, *Manager IT*

„We use Dell hardware in our company and we also wanted to run our Open-E High Availability Cluster on this platform. We were convincingly and competently consulted regarding the selection of suitable hardware as well as the subsequent configuration. The result is a High Availability Cluster with an outstanding price-performance ratio. Partly because ITgration GmbH understood how to implement the project in such a way that it perfectly met our requirements.“

# About Mitsui Chemicals

The Mitsui & Co. Deutschland GmbH of today was officially founded in 1954 and has been actively expanding the business ever since. We are particularly successful in our key business areas, ranging from chemicals and plastics to steel, infrastructure projects, mobility, information technology, logistics and food. Headquartered in Tokyo, Mitsui has a global network of 139 offices in 66 countries and more than 460 subsidiaries and affiliates worldwide. Our five most important functions are marketing, finance, logistics, risk management, IT and process development. We combine all of these functions to create and optimize value chains in numerous business areas. Our services are designed to deliver added value and to meet the diverse needs of our global customers. Find more info here: [www.mitsuichem.com](http://www.mitsuichem.com)

## About ITgration

ITgration's product portfolio includes supporting the entire IT department, from analysis and consulting to planning, installation and migration. As a responsible service provider, ITgration GmbH regards itself as the external IT department of the company and ensures the smooth functioning of the supported IT at all times. The development of proactive suggestions on how to make the entire IT environment more efficient and future-proof is part of our self-image as a service provider. As specialists for IT support, IT security, IT infrastructure and cloud solutions, ITgration GmbH offers the right solution for all of your requirements. More info here: [www.itgration.de](http://www.itgration.de)

## About Open-E

Open-E, founded in 1998, is a well-established developer of IP-based storage management software. Its flagship product Open-E JovianDSS is a robust, award-winning storage application which offers excellent compatibility with industry standards, and is the easiest to use and manage. Additionally, it is of the most stable solutions on the market and undisputed price performance leader. Thanks to its reputation, experience and business reliability, Open-E has become the technology partner of choice for industry-leading IT companies. Open-E accounts for over 30,000 installations world-wide and has received numerous industry awards and recognition, also with its product Open-E DSS V7. For further information about Open-E, its products and partners, visit [www.open-e.com](http://www.open-e.com)

### More information:

**Mitsui & Co. Deutschland GmbH**  
Tel: +49-211 - 9386-0 | [InfoDUSZZ@dg.mitsui.com](mailto:InfoDUSZZ@dg.mitsui.com)

**ITgration GmbH**  
+49 2103 930-910 | [info@itgration.de](mailto:info@itgration.de)

**Open-E GmbH**  
+49 (89) 800777 0 | [info@open-e.com](mailto:info@open-e.com)