

# open-e JovianDSS

## Open-E Advanced Metro HA Cluster

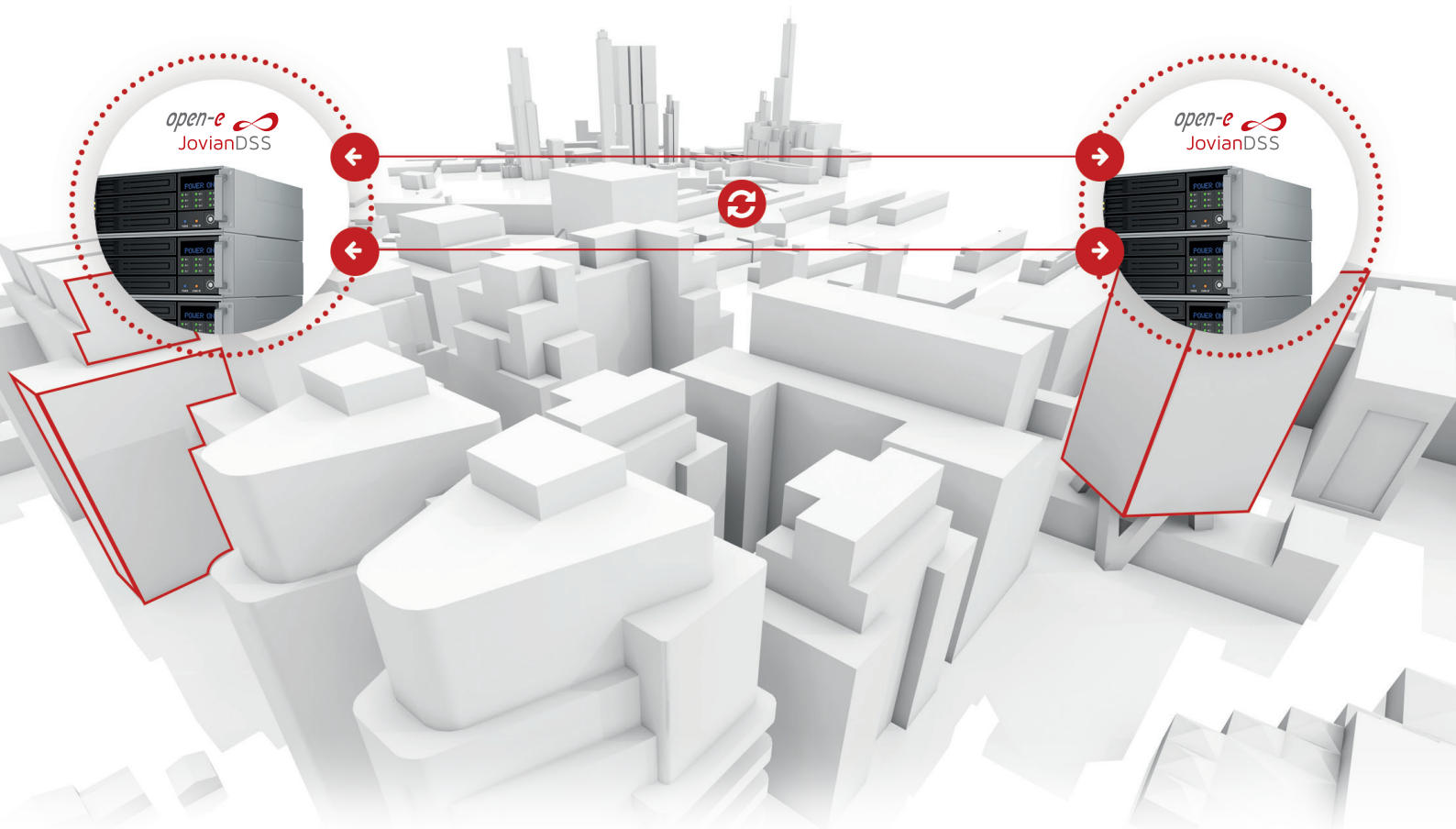

### Advanced Metro HA Cluster – Benefits

- » 1Gbps, 10Gbps, 40Gbps, 100Gbps Ethernet support for maximum speed
- » Perfect for both rack (from 12" / 30cm) and metro (up to 50 miles / 80km) clusters
- » Allows use of less expensive SATA drives
- » Easy to configure and manage
- » Compared to SAS or FibreChannel, JBODs are not required for Ethernet clusters
- » Optional use of RAID controllers

## Advanced Metro High Availability cluster for SMB, NFS and iSCSI

Open-E JovianDSS includes failover functionality for SMB, NFS and iSCSI, enabling you to set up High Availability Load-Balanced Storage Clusters that ensure reliability and redundancy through failover in case of a server crash. By using the Open-E JovianDSS Advanced Metro High Availability Cluster Feature Pack, you can create High Availability for two server nodes over Ethernet using a storage at each location (Dual Storage). Since the connection of cluster communication and data mirroring between nodes works over Ethernet, the nodes might be located far from each other as a (stretched) metro storage cluster. It can be 50 miles (80 km) in case of point to point fibre optic connection, or even more when using an additional switch between nodes - provided that network latency will not exceed 5 ms. The Feature Pack also supports configurations of the Open-E JovianDSS Standard HA Cluster Feature Pack.

### SAN (iSCSI) Failover

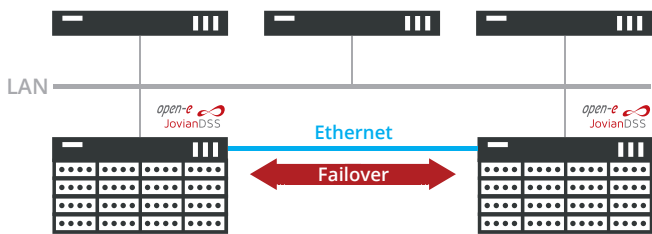

### NAS (SMB, NFS) Failover

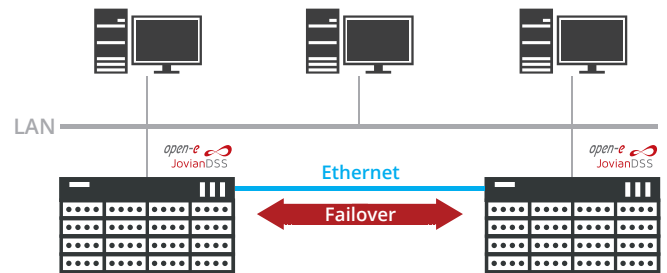

## Advanced HA cluster management

With the HA cluster management software functionalities allows you can quickly access all features related to your cluster setup. Whether for initial configuration or re-configuration after a failover – everything is in one place and guarantees ease of use for the storage administrator.

High availability capabilities	
HA cluster architecture	Physical drives shared between nodes
Metro storage cluster	Yes (SMB, NFS, iSCSI)
Independent Virtual IPs for HA Cluster	Yes
Max. clustered volume size	Unlimited
Max. clustered storage size	Unlimited
Persistent Reservation Synchronization	Yes

### High availability architecture examples:

Cluster in a Box (CiB)



Common Storage Cluster over SAS

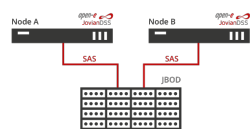

Cluster over SAS with internal expander



Cluster with multiple JBODs over SAS

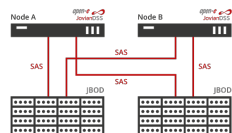

Cluster with multiple JBODs over FC

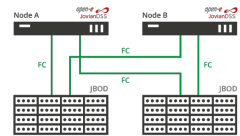

Cluster with multiple JBODs over SAS/FC (with ATTO bridges)

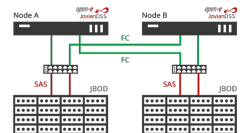

Cluster over Ethernet

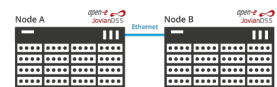

## Examples of deployments

With Open-E JovianDSS you can easily setup a Metro Cluster that best fits your individual needs, using various protocols, hardware components and virtualization platforms.

### Single VIP over Bond

Bonding for NFS / SMB, single iSCSI Path

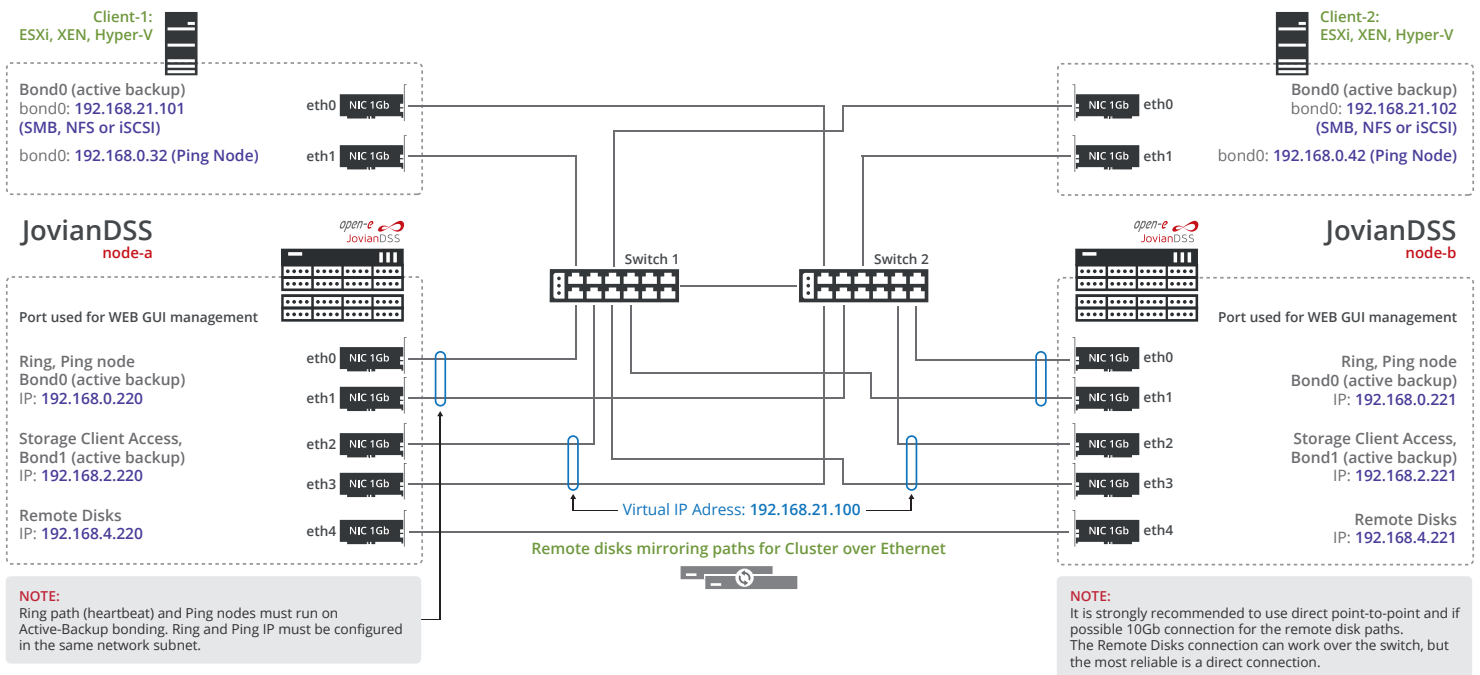

### Double VIP

Multipath iSCSI, single NFS / SMB Path

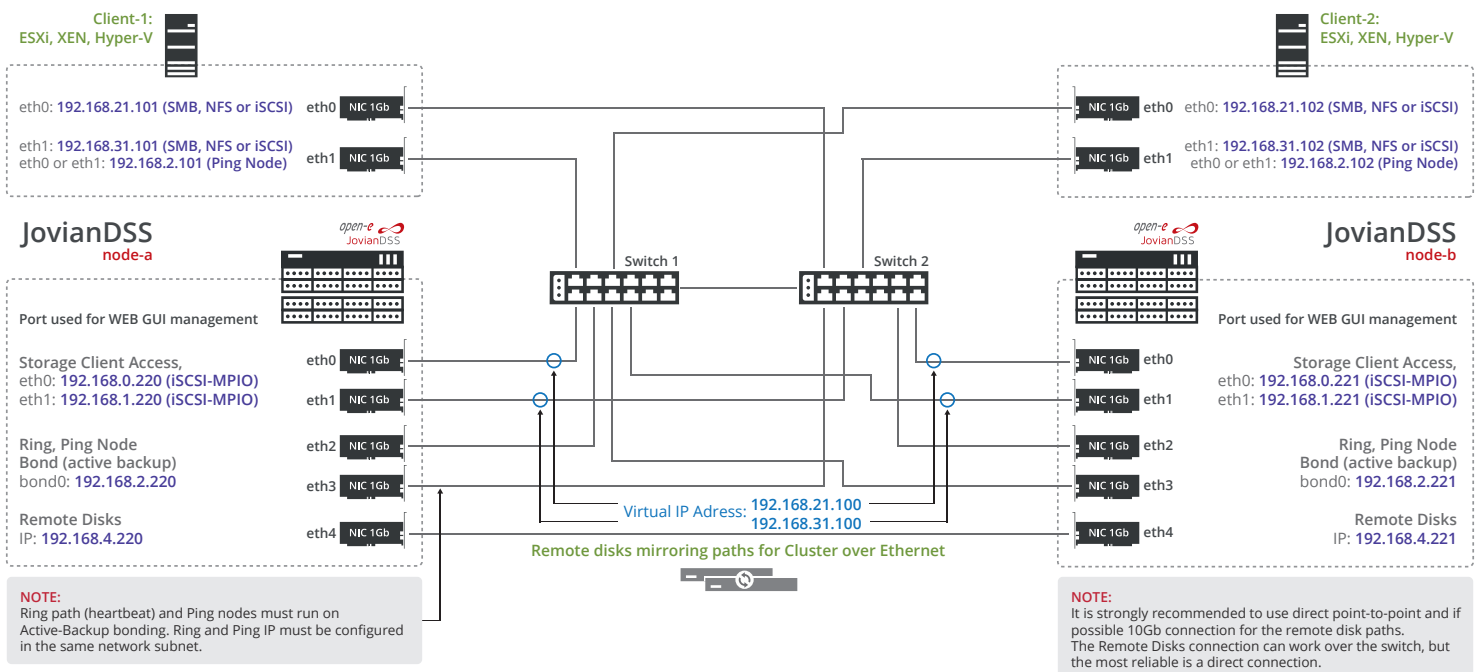

## Double VIP over Bonds

Multipath iSCSI, Bonding for NFS / SMB

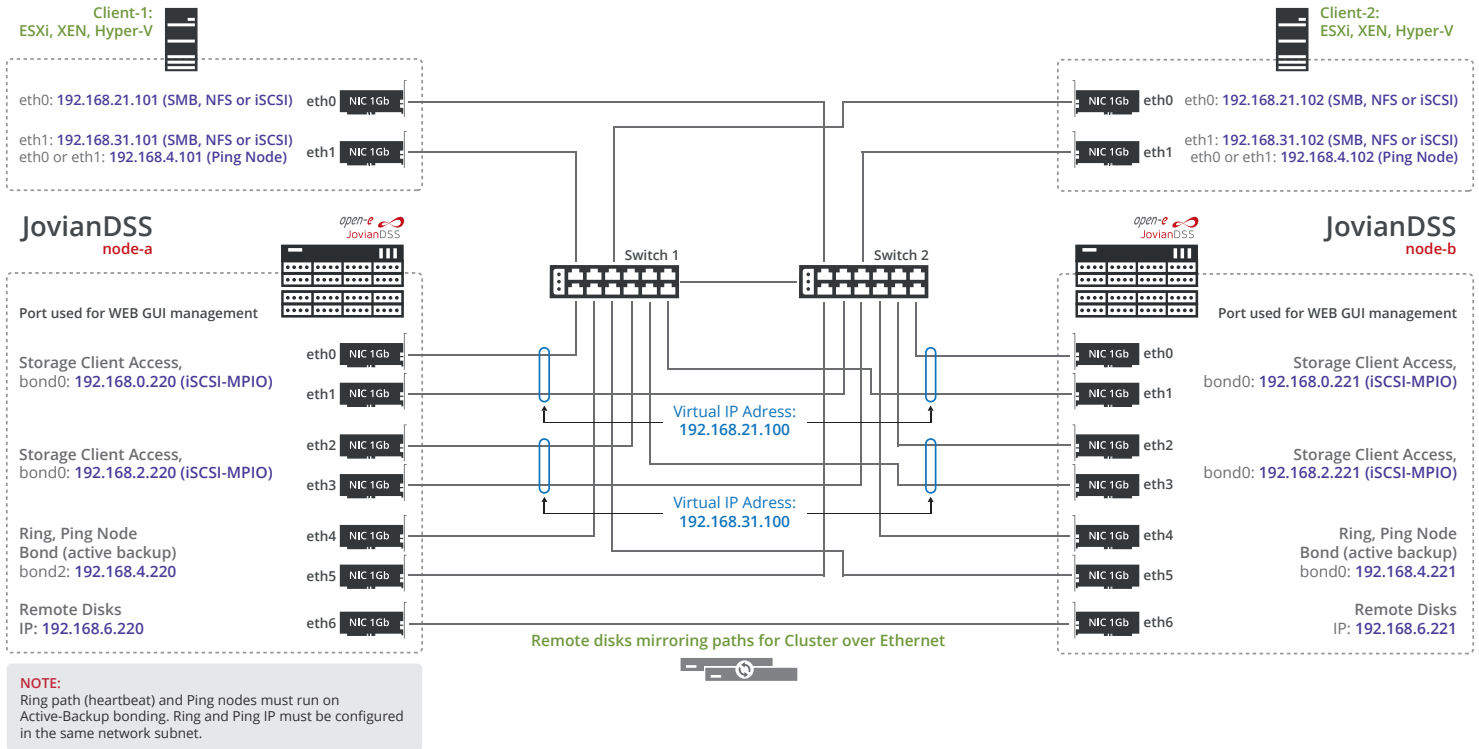

## Double VIP

Multipath iSCSI, single NFS / SMB Path, Bond for mirroring

