

Open-E & Hahn Automation Group

FLEXIBLE. HIGHLY AVAILABLE. FUTURE-READY

THE SDS STRATEGY OF HAHN AUTOMATION GROUP WITH OPEN-E JOVIANDSS

Key Facts:

- **Strategic Technology Shift:** Following an in-depth SDS evaluation, Open-E JovianDSS replaced the previous system due to superior performance, stability, and long-term viability.
- **Future-Proof Architecture:** NFS as the standard protocol enables seamless integration with both VMware and Proxmox – backed by official Open-E Best Practices support.
- **Scalability & Central Archive:** In addition to local clusters, Hahn Group operates a petabyte-scale archive system at headquarters – designed for group-wide access.
- **High Availability:** Dual data pools per site and a highly available central archive system ensure uninterrupted maintenance and continuous access to business-critical data.
- **Cost Efficiency & Usability:** ZFS functionality, an intuitive web GUI, reliable support, and the use of existing hardware deliver strong overall value.

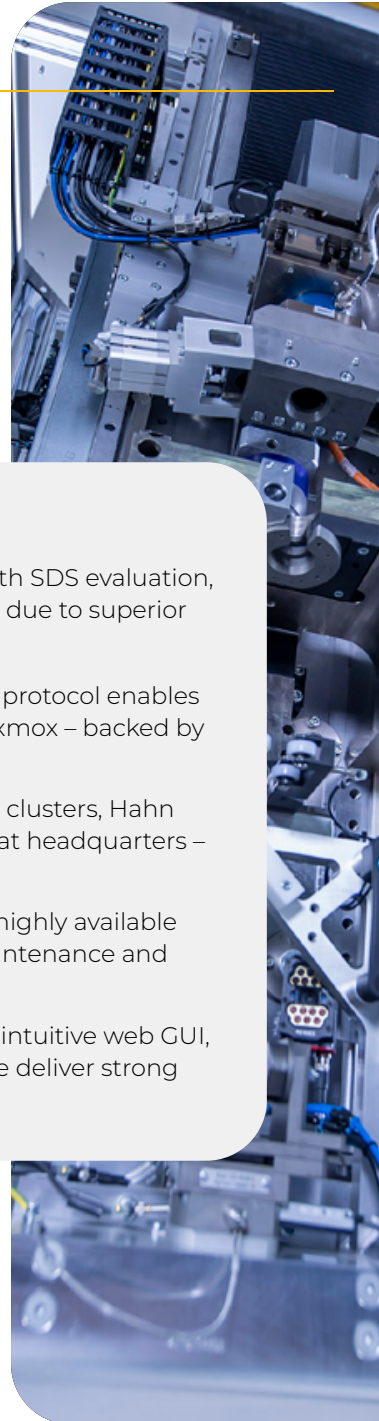

Requirements and Objectives

About the Hahn Automation Group

The HAHN Automation Group **is a global solution partner for factory automation.** The company stands for industry-specific expertise, a broad project portfolio, and a globally structured organization with integrated service from a single source. From manual workstations to semi-automated cells and fully automated production lines, 1,600 employees at 20 locations worldwide develop tailored automation solutions. In addition, the company's digital product portfolio provides manufacturing businesses with a competitive edge by increasing efficiency and paving the way toward the Smart Factory. Customers in the automotive, electronics, and medical technology sectors benefit from more than 30 years of experience and internationally driven innovation.

The Role of Data Storage in the Company

The **secure and long-term storage** of design and project data is business-critical for the Hahn Automation Group. Data must remain accessible for many years in order to be quickly available in cases such as service requests or spare part inquiries. At the same time, the volume of data is steadily increasing due to new projects, formats, and applications. **A scalable, high-availability storage architecture** is therefore a key component of the company-wide IT strategy.

Requirements at a Glance

- ✓ **Stability:** Implementation of an SDS solution with reliable operation and active product support.
- ✓ **Virtualization Support:** Integration with the existing VMware infrastructure as well as future migration to Proxmox.
- ✓ **High Availability:** Use of dual-node clusters and separate data pools to minimize downtime.
- ✓ **Cost Efficiency:** Reuse of existing hardware and avoidance of vendor-locked licensing models. Greater freedom of choice in hardware vendors – for example, there is no need for branded DELL shelves; direct sourcing from Seagate, WD, or similar suppliers is possible.
- ✓ **Centralized Management:** Unified administration and monitoring of all storage locations by the central IT team
- ✓ **Scalability:** Systems can be expanded step by step to accommodate growing data volumes.

Decision for a New SDS Platform

In previous years, the Hahn Automation Group had implemented **an initial SDS solution, which increasingly reached its limits** – both technically and in terms of support, scalability, and strategic development. Growing demands for performance, availability, and centralized management made a realignment necessary.

As part of an **extensive selection process, all relevant SDS solutions were systematically evaluated** – with a focus on flexibility, high availability, ZFS capabilities, virtualization integration, licensing models, and long-term operational reliability. **Open-E JovianDSS clearly stood out in this benchmark** and was introduced as the new strategic platform.

The licenses were procured through the distribution partner Thomas-Krenn.AG, who handled the acquisition for this project. From the outset of the **SDS strategy, the system architecture has been based on NFS** – deliberately avoiding iSCSI, as NFS proved to be the more robust and flexible solution within Hahn's environment, particularly for direct access by Linux VMs or applications such as Nextcloud.



Customer Statement

Ease of use and reliable support are decisive factors for us. Open-E JovianDSS is the most flexible solution for providing large-scale data storage quickly and efficiently.

Karl Lengsfeld, Senior Operations Specialist IT, Hahn Automation Group

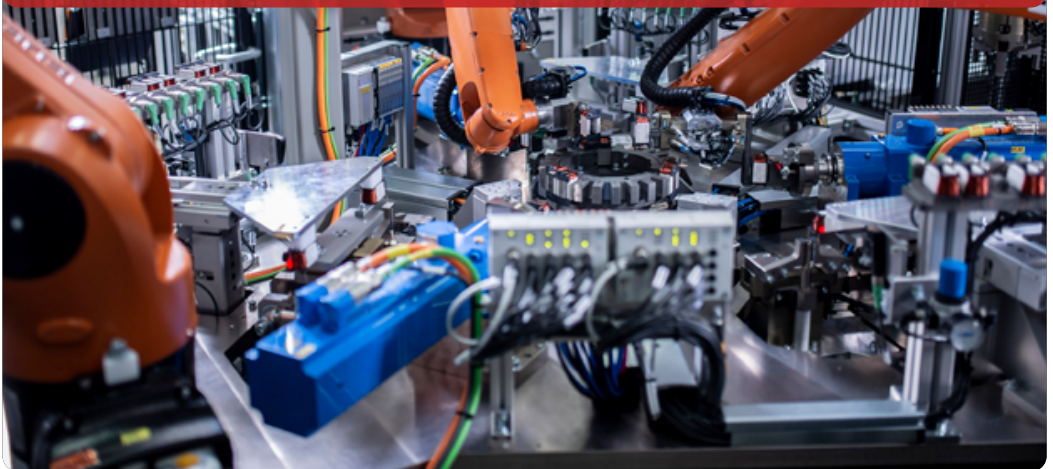

Solution

The Hahn Automation Group **operates dedicated SDS clusters based on Open-E JovianDSS at several key locations.** The architecture is designed for high availability: two ESXi hosts per site are connected via SAS to separate JBODs. These JBODs are assigned directly to the virtual Open-E JovianDSS instances using PCIe passthrough. Each JBOD contains its own active data pool – mirroring is intentionally not used. High availability is achieved through virtualization and the distribution of independent data pools.

Storage and compute are combined in a hyperconverged architecture: the Open-E VMs handle both storage and compute functions. This allows resources to be shared while remaining independently scalable. **Data is provided via the NFS protocol – a deliberate decision by the IT department.** Choosing NFS not only enables stable integration with VMware, but also lays the foundation **for fully supported deployment with Proxmox VE, following Open-E's best practices for high-availability, hypervisor-independent setups.**

One key advantage of Open-E JovianDSS is its **use of ZFS.** Unlike legacy systems based on Oracle ZFS, Open-E uses a modern and actively maintained implementation. This simplified the migration process and ensures long-term data integrity. The migration was carried out site by site via vMotion, using two independent data pools – with no downtime and minimal risk.

ZFS enables intelligent tiered caching. Write operations are secured by 400 GB SSD write log devices, while read-intensive access is accelerated via 800 GB read cache SSDs. Depending on the location, available RAM ranges from 100 GB to over 270 GB. **All clusters are centrally managed by the IT team in Rheinböllen.** Monitoring is performed using Icinga with SNMP integration and Open-E JovianDSS-specific plugins. Snapshot functionality has been successfully tested in initial scenarios and is planned to be expanded across all sites.

Results

- ✓ **Operational Stability:** The ZFS-based architecture has proven itself in production – with zero downtime, clearly defined failover behavior, and consistent data access.
- ✓ **Efficiency in Management and Costs:** Leveraging existing hardware, an intuitive GUI, and competent support reduces both ongoing and operational effort.
- ✓ **Flexibility for Future Requirements:** NFS integration, VMware compatibility, and Proxmox readiness provide room for technological evolution and site-specific adjustments.

Storage Architecture and Hardware

The diagram illustrates the typical storage architecture at each site: two ESXi hosts running Open-E JovianDSS VMs, connected via PCIe passthrough to a JBOD with separate ZFS data pools. Connectivity is established via NFS virtual IPs, with cluster communication handled through a heartbeat mechanism. **The architecture is fault-tolerant, flexible, and hardware-independent.**

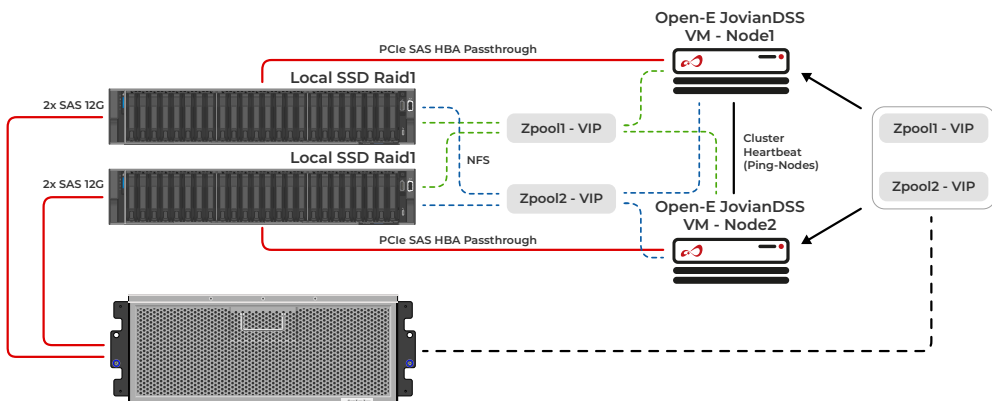

The hardware used varies by location – a key advantage of Open-E JovianDSS's hardware-independent SDS architecture. The following table lists sample components:

Hardware Overview

Component	Variants in Use
CPU	- 2× Intel Xeon Gold 6128 3.4 GHz - 2× Intel Xeon Silver 4110 / 4210 - 1× AMD EPYC 7542
Server Model	- HPE ProLiant DL380 Gen10 - Dell PowerEdge R7525 - Dell PowerEdge R7515
SAS HBA	- HPE E208e-p SR Gen10 - Dell 12Gbps HBA
JBOD	- WD Ultrastar Data60 SE4U60 - HGST 4U60 - Seagate Exos E5U84
ARC Cache (RAM)	50 GB bis 384 GB (depending on location)

Data Storage Configuration

High Availability	Dual-node cluster at each site with shared storage via SAS JBOD and active data pools per node – connected via PCIe passthrough.
Redundancy	ZFS mirror or RAIDZ (depending on location), each configured as an independent pool within the JBOD.
Performance & Data Integrity	SSD write log, read cache, ZFS self-healing, and separate pools for increased resilience.

Data Storage OS Licenses

10 × Open-E JovianDSS Product License (0 TB base license)	Base license per node
4 × 32 TB Open-E JovianDSS Storage Extension	for scaling smaller systems
6 × 128 TB Open-E JovianDSS Storage Extension	for medium to large data volumes
2 × 1280 TB Open-E JovianDSS Storage Extension	for multi-site archive and backup scenarios
10 × Open-E JovianDSS Advanced Metro HA Cluster Feature Pack	for securing dual-node clusters with high availability

Support: 6 × Premium Support. 4 × Standard Support



Petabyte-Scale Archive Solution – Central Open-E Cluster for All Locations

The Hahn Automation Group operates a **high-performance archive system at its headquarters in Rheinböllen, based on Open-E JovianDSS – the largest cluster within the group and a key element of its IT strategy.** It is used for long-term archiving, internal access to historical project data, and centralized backup, offering petabyte-scale storage capacity and full high availability.

Technically, the system consists of two ESXi hosts with Open-E VMs in a high-availability cluster, connected via redundant SAS links to SEAGATE JBODs. The configuration includes 76 × 18 TB HDDs, 2 × 800 GB ARC SSDs, and 4 × 1.6 TB SLOG SSDs. Data is delivered through a dedicated storage VLAN.

Access is provided internally via applications such as Citrix – direct NFS access from remote locations is not intended. Nevertheless, **service technicians and departments can access archived data easily and independently of their physical location.**

Benefits:

- ✓ **Petabyte-scale archive system based on Open-E JovianDSS**, implemented independently of specific hardware
- ✓ Centralized archiving with access via applications (e.g., Citrix); no direct NFS access from remote locations
- ✓ Fully integrated into the virtualized IT infrastructure
- ✓ Ideal for **long-term archiving, service access, and centralized backup strategies**

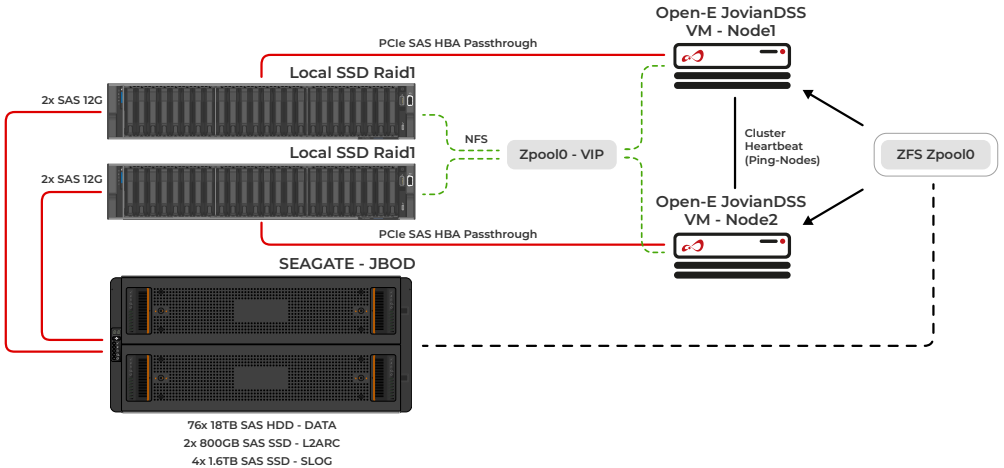

The key advantages of Open-E JovianDSS that meet the requirements of the Hahn Automation Group at a glance:

- ✓ **High Availability:** Dual-node clusters with independent data pools at each location
- ✓ **Flexibility:** The NFS-based architecture allows full integration with both VMware and Proxmox – enabling maximum independence in hypervisor choice
- ✓ **Scalability:** Expandable storage capacities thanks to a modular ZFS architecture
- ✓ **Performance:** ZFS with SSD caching devices
- ✓ **User-Friendliness:** Intuitive management via web GUI and centralized control
- ✓ **Data Security:** ZFS checksums, snapshot functionality, and support for future backup integrations
- ✓ **Central Archive:** The archive solution in Rheinböllen provides petabyte-scale storage for all locations – designed for high availability, ideal for long-term data retention, service access, and cross-system protection

Interested in a similar solution? Contact us for a non-binding consultation.



About the Hahn Automation Group

The HAHN Automation Group is a global solution partner for factory automation. The company stands for industry-specific expertise, a broad project portfolio, and a globally structured organization with a strong service focus – all from a single source. From manual workstations and semi-automated cells to fully automated production lines, 1,600 employees at 20 locations worldwide deliver customized solutions. In addition, the company's digital product portfolio gives manufacturing businesses a competitive edge by increasing efficiency and paving the way to the Smart Factory. Customers in the automotive, electronics, and MedTech industries benefit from expertise built on over 30 years of experience and international innovation.

More information: www.hahnautomation.group

About Open-E

Founded in 1998, Open-E is a leading developer of IP-based storage management software. Its flagship product, Open-E JovianDSS, is a robust storage application known for excellent compatibility with industry standards, as well as ease of use and administration. It is also one of the most stable solutions on the market, offering outstanding value for money.

Thanks to its reputation, experience, and reliability, Open-E is a trusted technology partner to leading IT companies. With over 40,000 installations worldwide and numerous industry awards, Open-E continues to be a driving force in storage innovation.

For more information about Open-E, its products, and partners, visit: www.open-e.com.



Contact:

- **Hahn Automation Group** → www.hahnautomation.group
- **Open-E GmbH** → +49 898007770 / info@open-e.com